

DE

Bedienungsanleitung - Schlauchaufroller R3

GB

Instruction booklet - Hose Reel R3

FR

Manual de mode d'emploi - Enrouleur R3

ES

Manual de instrucciones - Enrolladore R3

IT

Libretto di istruzioni - Avvolgitubo R3

DE Inhaltsverzeichnis

1.	Allgemeine Hinweise	6
2.	Installation	6
3.	Feder spannen	7
4.	Austausch des Schlauches	7
5.	Austausch Drehkörper und Dichtung	8
6.	Lösen / Austausch Deckel	9
7.	Fehlerbehebung	10

GB Index

1.	General warnings	11
2.	Installation	11
3.	Increase spring tension	12
4.	Hose replacement instructions	12
5.	Replacement swivel and seal	13
6.	Remove / replace side plate	14
7.	Trouble shooting	15

FR Sommaire

1.	Consignes générales	16
2.	Installation	16
3.	Tendre le ressort	17
4.	Remplacement du tuyau	17
5.	Remplacement du tambour et du joint	18
6.	Extraction / remplacement du cache	19
7.	Résolution de problèmes	20

ES Índice

1.	Indicaciones generales	21
2.	Installation	21
3.	Tensión del muelle	22
4.	Sustitución de la manguera	22
5.	Sustitución del pivote y de la junta	23
6.	Extracción / sustitución de la tapa	24
7.	Resolución de problemas	25

IT Indice

1.	Indicazioni generali	26
2.	Installation	26
3.	Tendere la molla	27
4.	Sostituire il tubo flessibile	27
5.	Sostituire il raccordo girevole e la guarnizione	28
6.	Rimuovere / sostituire il coperchio	29
7.	Risoluzione die problemi	30

DE

EN

FR

ES

IT

Ersatzteile / Spare Parts / pièces détachées / piezas de repuesto / ricambi

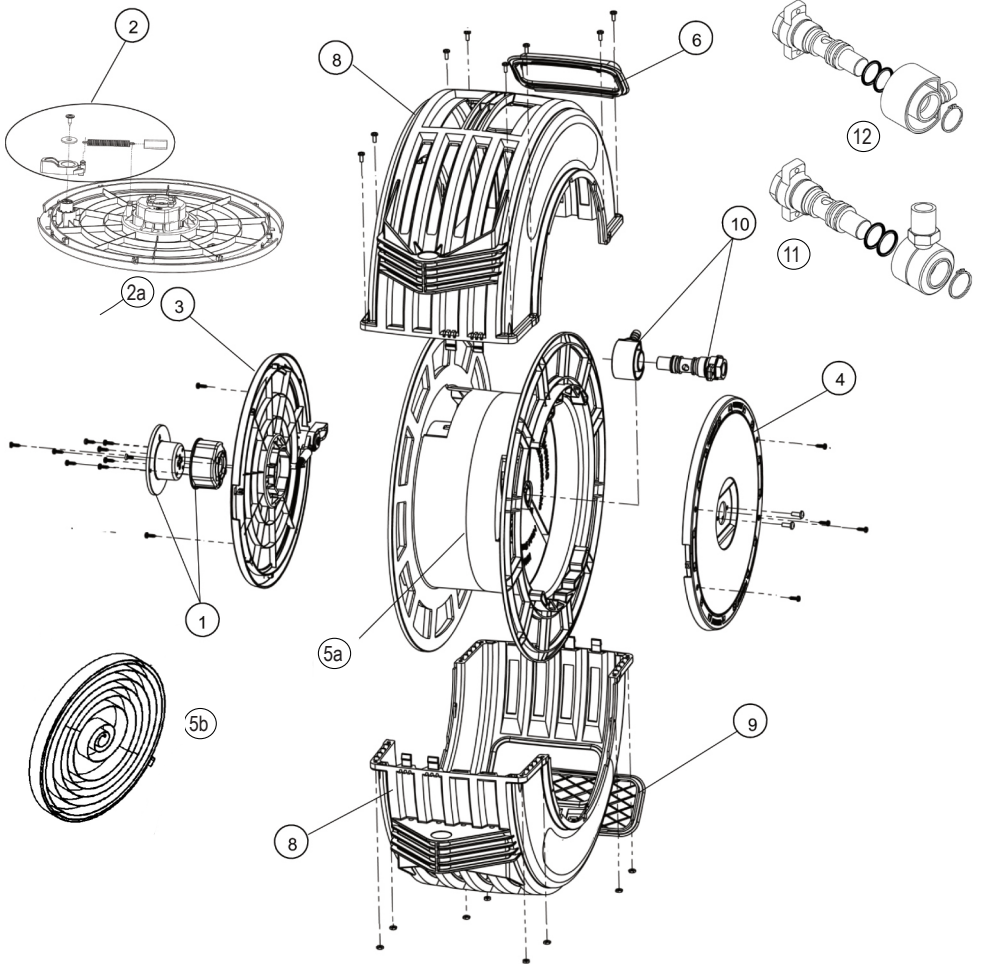

No.	Item-No.	No.	Item-No.
1	012-R31HS	7	1.100.002
2	012-R3LS	8	012-R3OCTD
2a	012-RP155	9	012-R3LIS
3	012-R3LPS	10	012-RS1S DR 100, 110, 200, WP 100
4	012-R3IPS		012-RS1S3 DR300
5a	012-R3DAS1 012-R3DAS		012-RS26S AR100
			012-RS46S AR200
5b	N000293 N000296	11	012-BS115
6	012-R3MS	12	012-Z9S

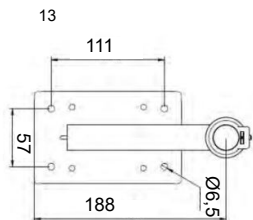
DE**EN****FR****ES****IT****Ersatzteile / Spare Parts / pièces détachées / piezas de repuesto / ricambi**

No.	Item-No.
13	1.100.003
14	1.100.004

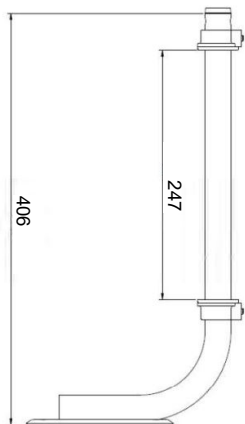

14

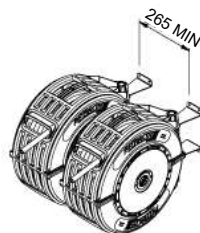
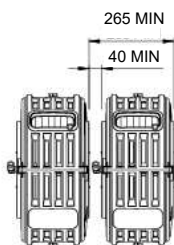
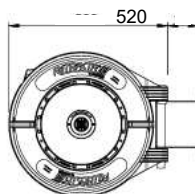
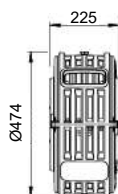
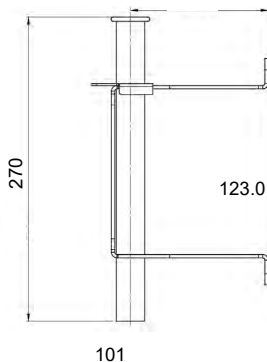
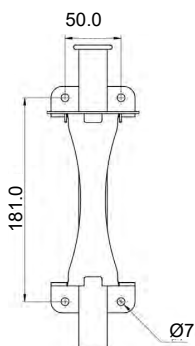

DE**EN****FR****ES****IT**

DE	Schlauch, lose	Anschlusschlauch lose	Schlauch komplett mit Armatur	Anschlusschlauch komplett mit Armatur	Spritzpistole
GB	single hose	single connection hose	Hose complete with fitting	connection hose with fitting	Spray gun
FR	tuyau unique	Tuyau de raccordement unique	Tuyau complet avec raccord	Tuyau de raccordement complet avec raccord	Pistolet à peinture
ES	Manguera simple	Manguera de conexión simple	Manguera completa con accesorio	Manguera de conexión completa con racor	Pistola
IT	Tubo singolo	tubo di collegamento singolo	Tubo flessibile completo con raccordo	Tubo di collegamento completo di raccordo	Pistola a spruzzo
					
DR 100	130.802	130.841	ES10204	ES10209	130.141
DR 200	130.839	130.842	ES10205	ES10210	130.140
DR 300	130.840	130.843	ES10206	ES10211	130.140
AR 100	130.849	-	ES10207	130.236	-
AR 200	130.850	-	ES10208	130.236	-

DE

EN

FR

ES

IT



Vor Inbetriebnahme des Gerätes die Bedienungsanleitung aufmerksam lesen!

1. Allgemeine Hinweise

Der Schlauchaufroller ist mit einem Federrückzug zur Schlauchaufwicklung ausgestattet. Der Schlauch kann bei jeder Umdrehung mit der Arretierung fixiert werden. Der Schlauchaufroller darf ausschließlich zum Aufwickeln von Schläuchen verwendet werden. Für die verschiedenen Modelle dürfen ausschließlich Schläuche für die unten aufgeführten Medien mit jeweiligem Arbeitsdruck verwendet werden.

Modell	Medium/ max. Temperatur	Max. Arbeitsdruck
DR 100 - 300 R3	Kaltwasser + 50°C	8 bar
DR 110 R3	Kaltwasser + 50°C	8 bar
AR 100 - 200 R3	Druckluft + 50°C	17 bar
HWP 100 R3	Heißwasser + 50°C	200 bar
WP 100 R3	Pflanzenschutzmittel + 50°C	17 bar

Folgende Hinweise sind bei der Installation, Inbetriebnahme und Wartung des Schlauchaufrollers zu beachten. Weitere Hinweise zu speziellen Gefahren sind im weiteren Verlauf der Bedienungsanleitung zu finden.

- Überschreiten Sie niemals den auf dem Schlauchaufroller angegebenen Arbeitsdruck.
- Schlauch und Schlauchaufroller dürfen nur mit Flüssigkeiten in Kontakt kommen, für die sie geeignet sind
- Prüfen Sie täglich den Schlauch und Schlauchaufroller auf Verschleiß und Undichtigkeit. Defekte Teile müssen sofort und nur mit original Ersatzteilen ersetzt werden.
- Schlauchaufroller nur für den vorgegebenen Verwendungszweck benutzen.
- Schlauchaufroller nicht ändern oder modifizieren.
- Den Schlauch beim Herausziehen und Aufwickeln niemals loslassen.
- Niemals versuchen, Undichtigkeiten am Schlauch und Schlauchaufroller mit der Hand oder anderen Körperteilen abzudichten.

ACHTUNG:

Vor Wartung oder Reparatur immer die Medienzufuhr abklemmen und Schlauchaufroller „drucklos“ machen.

2. Installation

Beachten Sie folgende Punkte bei der Installation des Schlauchaufrollers:

- Verwenden Sie Montagematerial, welches geeignet ist, das Gewicht des Schlauchaufrollers zu tragen. Beachten Sie hierbei auch das Gewicht der Flüssigkeit und die Federspannung.
- Bei Deckenmontage (Abb. 2) darf der Schlauchaufroller nicht schwenkbar sein. Verwenden Sie dazu die mitgelieferte Fixierung.
- Verwenden Sie eine Schraube M8x50, um den Bolzen des Wandhalters zu fixieren. Alternativ kann auch ein Vorhängeschloss verwendet werden.
- Stellen Sie eine sichere und dichte Verbindung als Flüssigkeitsversorgung mit dem seitlichen Anschluss her. Beachten Sie den maximalen Arbeitsdruck des Schlauchaufrollers.
- Prüfen Sie den Schlauchaufroller auf Dichtigkeit.



Abb. 1 - Wandmontage, max. Höhe 1,4 m



Abb. 2 - Deckenmontage, max. Höhe 4,5 m

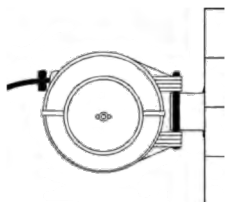

Abb. 3 - Bodenmontage (Zubehör)

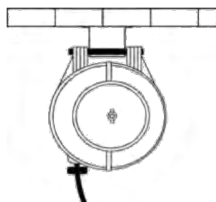

Abb. 4 - Wandmontage, max. Höhe 4,5 m (Zubehör)

3. Feder spannen

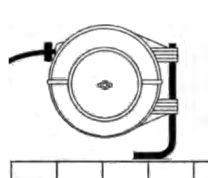
ACHTUNG: Vor allen Wartungsarbeiten muss der Schlauchaufroller „drucklos“ gemacht werden. Der Schlauch muss immer komplett aufgewickelt sein.

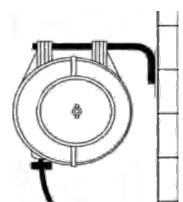

Abb. 1 - Lösen Sie die Schrauben



Abb. 2 - Drehen Sie im Uhrzeigersinn nach 1. „Klick“ entspricht 90°

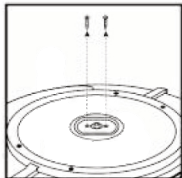

Abb. 3 - Drehen Sie die 2 Schrauben vorsichtig ein

4. Austausch des Schlauches

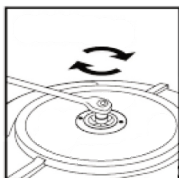
ACHTUNG: Vor allen Wartungsarbeiten muss der Schlauchaufroller „drucklos“ gemacht werden. Der Schlauch muss immer komplett abgewickelt sein.

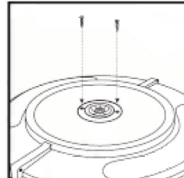

Abb. 1 - Schlauch komplett herausziehen und arretieren



Abb. 2 - Schrauben lösen

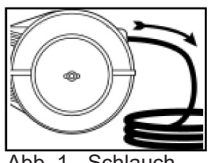

Abb. 3 - Schrauben lösen

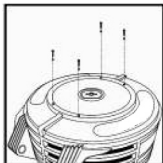

Abb. 4 - Deckel abnehmen

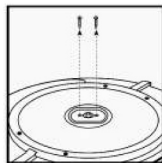

Abb. 5 - Kabelbinder entfernen



Abb. 6 - Drehkörper entfernen

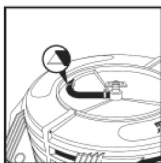

Abb. 7 - Schlauch entfernen

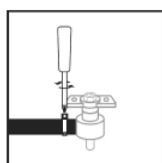

Abb. 8 - Schlauch einbauen



Abb. 9 - Schlauch an Drehkörper montieren



Abb. 10 - Drehkörper einbauen

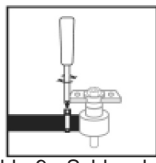

Abb. 11 - Kabelbinder montieren



Abb. 12 - Deckel montieren

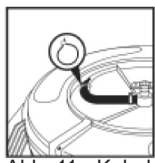

Abb. 13 - Schrauben eindrehen



Abb. 14 - Schrauben eindrehen

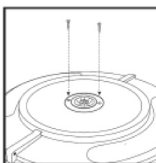

Abb. 15 - Schlauch gleichmäßig aufrollen

5. Austausch Drehkörper und Dichtung

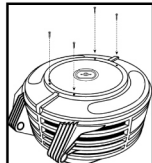
ACHTUNG: Vor allen Wartungsarbeiten muss der Schlauchaufroller „drucklos“ gemacht werden. Der Schlauch muss immer komplett abgewickelt sein.

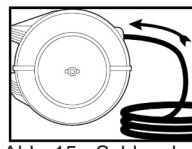

Abb. 1 - Schlauch komplett herausziehen und arretieren



Abb. 2 - Schrauben lösen

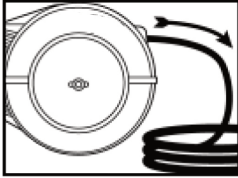

Abb. 3 - Schrauben lösen

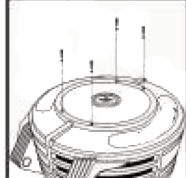

Abb. 4 - Deckel abnehmen

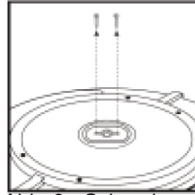

Abb. 5 - Kabelbinder entfernen



Abb. 6 - Seegerring entfernen



Abb. 7 - Drehkörper von Achse entfernen. O-Ringe einsetzen vor dem Einsetzen schmieren

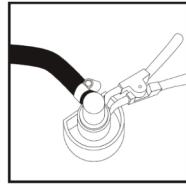

Abb. 8 - Schlauch an Drehkörper montieren

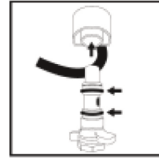

Abb. 9 - Drehkörper einbauen

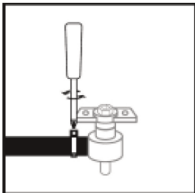

Abb. 10 - Kabelbinder montieren

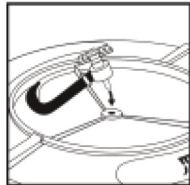

Abb. 11 - Deckel montieren

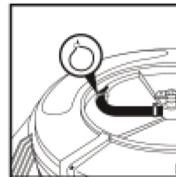

Abb. 13 - Schrauben eindrehen



Abb. 14 - Schrauben eindrehen

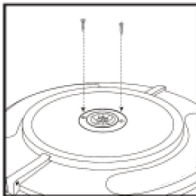

Abb. 15 - Schlauch gleichmäßig aufrollen

6. Lösen / Austausch Deckel

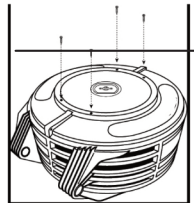
ACHTUNG: Vor allen Wartungsarbeiten muss der Schlauchaufroller „drucklos“ gemacht werden. Der Schlauch muss immer komplett abgewickelt sein.

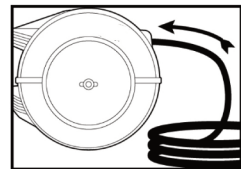

Abb. 1 - Schrauben lösen



Abb. 2 - Festhalten und 2 Schrauben lösen

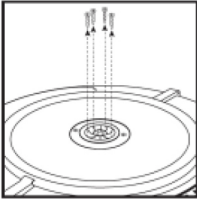

Abb. 3 - Feder entspannen

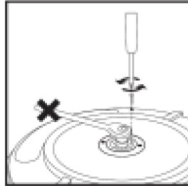

Abb. 4 - Schrauben lösen

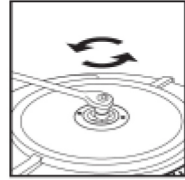

Abb. 5 - Festhalten und 2 Schrauben lösen

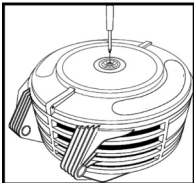

Abb. 6 - Deckel abnehmen

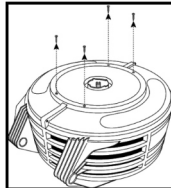

Abb. 7 - Neuen Deckel einsetzen

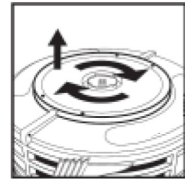

Abb. 8 - Schrauben einsetzen



Abb. 9 - Schrauben einsetzen

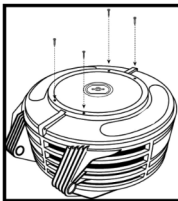

Abb. 10 - Schraube einsetzen

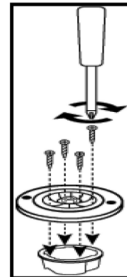

Abb. 11 - 3 Umdrehungen spannen

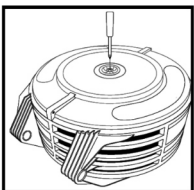

Abb. 12 - Schrauben einsetzen

7. Fehlerbehebung

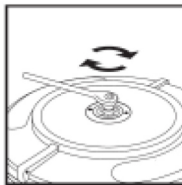
**Problem:**

Schlauch zieht sich langsam oder nicht komplett ein

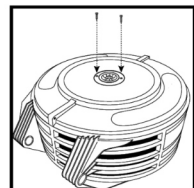
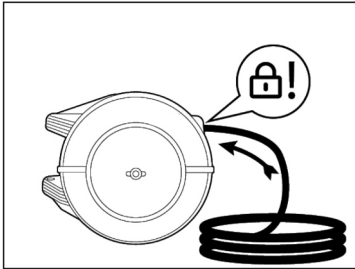
- a) Düse / Werkzeug am Schlauchende zu schwer
- b) Feder hat Spannung verloren

Lösung:

Feder nachspannen (siehe Kapitel 3)

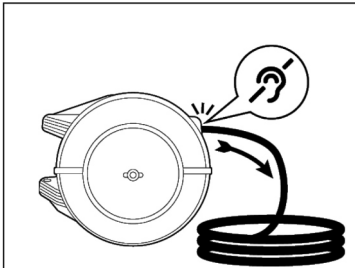
**Problem:**

Schlauchaufroller arretiert nicht

- a) Fehlerhafter Betrieb
- b) Arretierung defekt

Lösung:

Arretierung austauschen (siehe Kapitel 6)

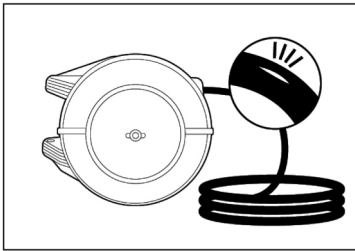
**Problem:**

Schlauch ist undicht

- a) Schlauch defekt

Lösung:

Schlauch austauschen (siehe Kapitel 4)

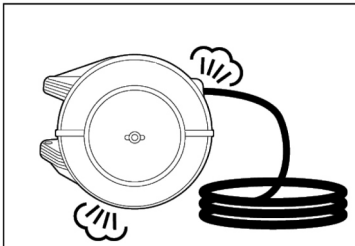
**Problem:**

Drehkörper ist undicht

- a) Drehkörper oder Dichtung defekt

Lösung:

Drehkörper oder Dichtung austauschen (siehe Kapitel 5)

 **Carefully read this instruction booklet before using the equipment!**

1. General warnings

The hose reel is equipped with a spring return for hose rewinding. The hose can be fixed with the lock at every turn. The hose reel may only be used for winding up hoses. For the various models, only hoses for the media listed below with the respective working pressure may be used.

Modell	Media/ max. temp.	Max. pressure
DR 100 - 300 R3	cold water + 50°C	8 bar
DR 110 R3	cold water + 50°C	8 bar
AR 100 - 200 R3	compressed air + 50°C	17 bar
HWP 100 R3	hot water + 50°C	200 bar
WP 100 R3	pesticides + 50°C	17 bar

The following general warnings should be observed when installing, operating or maintaining hose reel equipment. Further specific warnings pertaining to specific dangers may be found within this document

- Do not exceed the maximum working pressure for this reel (refer to the product specifications).
- Only use compatible fluids with this reel (refer to compatible fluids in product specifications)
- Check equipment daily for wear, damage or leaks. Replace worn or damaged items immediately with genuine replacement parts.
- Use equipment for intended use only.
- Do not alter or modify equipment.
- Do not let go of the hose when rewinding
- Do not attempt to stop leaks with your hand or body

Attention:

Before attempting any maintenance disconnect and turn of supply line, then release the line pressure.

2. Installation

Observe the following points when installing the hose reel:

- -Use mounting material that is suitable to support the weight of the hose reel. Also take into account the weight of the liquid and the spring tension.
- For ceiling mounting (Fig. 2), the hose reel must not be able to swivel. Use the fixation provided for this purpose.
- Use an M8x50 screw to fix the bolt of the wall bracket. Alternatively, a padlock can be used.
- Make a secure and tight connection as a liquid supply with the side connection. Observe the maximum working pressure of the hose reel.
- Check the hose reel for tightness.

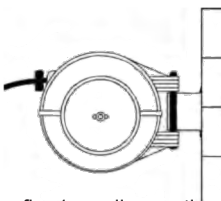

fig. 1 - wall mounting
max. height 1,4 m

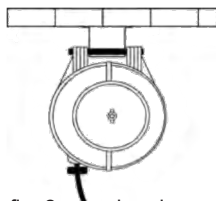

fig. 2 - overhead
mounting, max. height
4,5 m

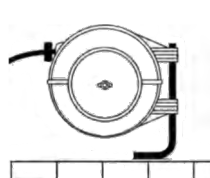

fig. 3 - bracket-floor/
bench (accessories)

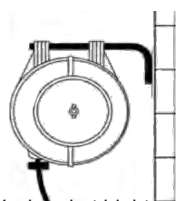

fig. 4 - bracket high wall
mounting, max. height 4,5 m
(accessories)

3. Increase spring tension

Attention: Before attempting any maintenance disconnect and turn of supply line, then release the line pressure. The hose must always be completely wound up.

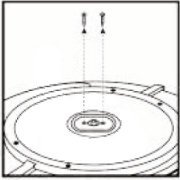

fig. 1 - remove screws

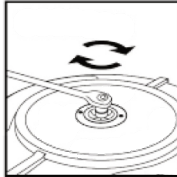

fig. 2 - add 2 complete turns. 1 click on hub equals 90°

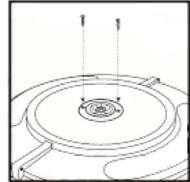

fig. 3 - replace screws

4. Hose replacement instructions

Attention: Before attempting any maintenance disconnect and turn of supply line, then release the line pressure. The hose must always be completely wound up.

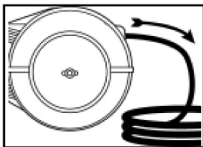

fig1. - pull out hose and latch

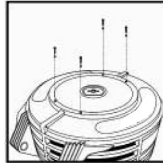

fig. 2 - remove screws

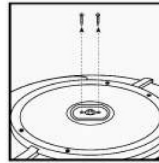

fig. 3 - remove screws

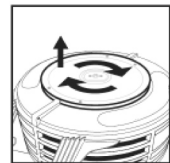

fig. 4 - Remove side plate



fig. 5 - remove cable tie

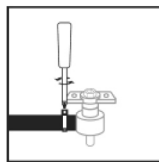

fig. 6 - remove swivel

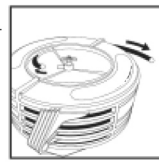

fig. 7 - remove hose



fig. 8 - fit hose

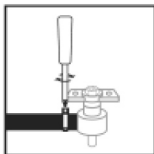

fig. 9 - attache hose to the swivel

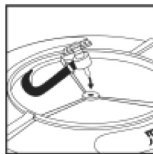

fig. 10 - fit swivel

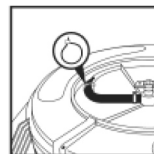

fig. 11 - fit cable tie

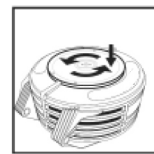

fig. 12 - fit side plate

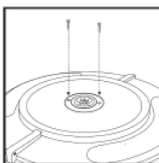

fig. 13 - fit screws

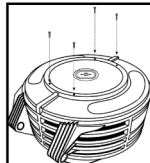

fig. 14 - fit screws

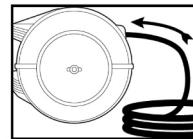

fig. 15 - recoil hose evenly into reel

5. Replacement swivel and seal

Attention: Before attempting any maintenance disconnect and turn off supply line, then release the line pressure. The hose must always be completely wound up.

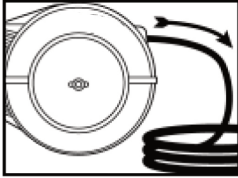

fig. 1 - pull out hose and latch

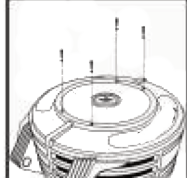

fig. 2 - remove screws

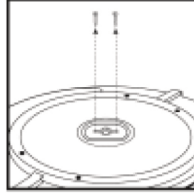

fig. 3 - remove screws



fig. 4 - remove plate



fig. 5 - remove cable tie

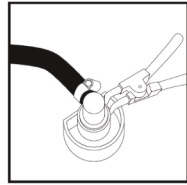

fig. 6 - remove circlip

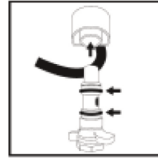

fig. 7 - remove body from shaft.
Replace o-Rings, apply suitable grease before mounting

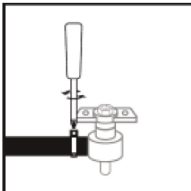

fig. 8 - attache hose to the swivel

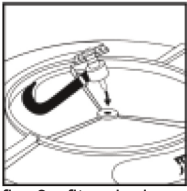

fig. 9 - fit swivel

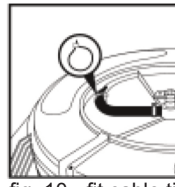

fig. 10 - fit cable tie



fig. 11 - fit side plate

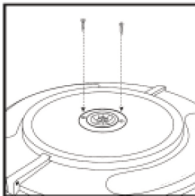

fig. 13 - fit screws

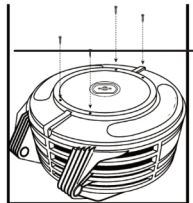

fig. 14 - fit screws

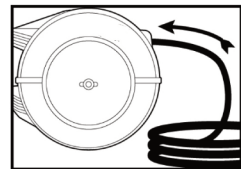

fig. 15 - recoil hose evenly to the reel

6. Remove / replace side plate

Attention: Before attempting any maintenance disconnect and turn off supply line, then release the line pressure. The hose must always be completely wound up.

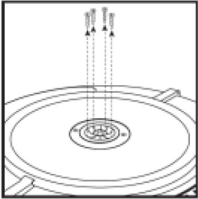

fig. 1 - remove screws

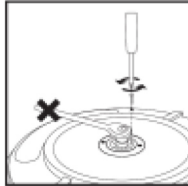

fig. 2 - hold up and remove 2 screws

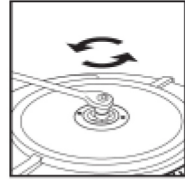

fig. 3 - release spring tension

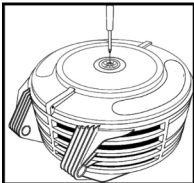

fig. 4 - remove screws

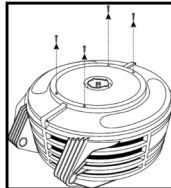

fig. 5 - hold up and remove 2 screws

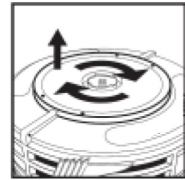

fig. 6 - remove plate

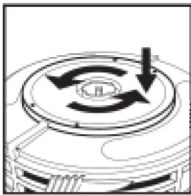

fig. 7 - fit new side plate

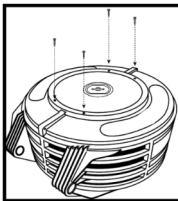

fig. 8 - fit screws

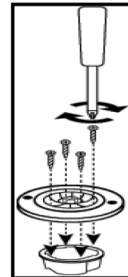

fig. 9 - fit screws

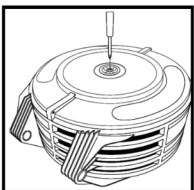

fig. 10 - fit screw

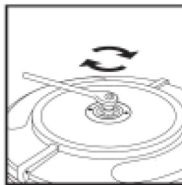

fig. 11 - add 3 complete turns

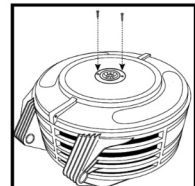
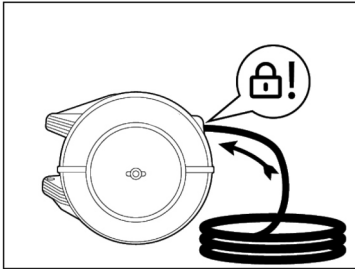

fig. 12 - fit screws

7. Trouble shooting



Problem:

Hose rewinds slowly or not complete

- a) Nozzle / gun is too heavy
- b) Spring has lost tension

Solution:

Increase spring tension (chapter 3)

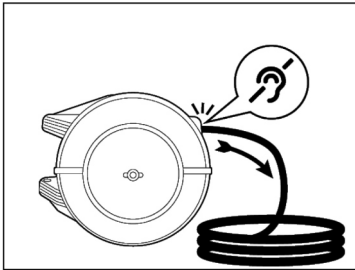

Problem:

Reel does not latch

- a) Incorrect operation
- b) Latch is broken

Solution:

Remove / replace tension side platze (chapter 6)

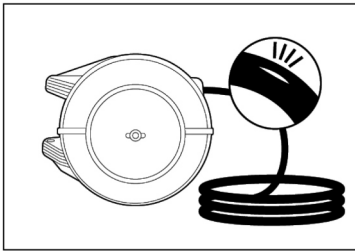

Problem:

Leaking from hose

- a) Split in hose

Solution:

Replace hose (chapter 4)

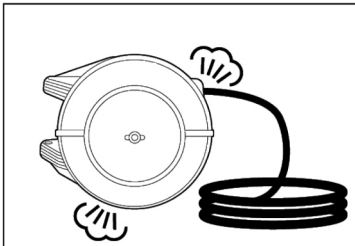

Problem:

Leaking from swivel

- a) Swivel or seals are worn

Solution:

Replacement swivel and seal (chapter 5)

DE

EN

FR

ES

IT



Lisez attentivement le mode d'emploi avant de mettre l'équipement en marche!

1. Consignes générales

L'enrouleur est doté d'un ressort de rappel permettant l'enroulement du tuyau. Un dispositif permet de bloquer le tuyau à chaque rotation. L'enrouleur doit exclusivement être utilisé pour l'enroulement de tuyaux. Pour les différents modèles, seuls doivent être utilisés des tuyaux pour les fluides stipulés ci-dessous à la pression de travail correspondante.

Modell	Fluide/ Temp. max.	Pression max.
DR 100 - 300 R3	eau froide + 50°C	8 bar
DR 110 R3	eau froide + 50°C	8 bar
AR 100 - 200 R3	air comprimé + 50°C	17 bar
HWP 100 R3	eau chaude + 50°C	200 bar
WP 100 R3	pesticides + 50°C	17 bar

Les consignes suivantes doivent être observées pour l'installation, la mise en service et la maintenance de l'enrouleur. D'autres observations concernant des risques spécifiques sont mentionnées dans la suite du mode d'emploi.

- Ne dépassez jamais la pression de travail indiquée sur l'enrouleur.
- Le tuyau et l'enrouleur ne doivent entrer en contact qu'avec des liquides avec lesquels ils sont compatibles.
- Vérifiez quotidiennement l'usure et l'étanchéité du tuyau et de l'enrouleur. Les pièces défectueuses doivent être immédiatement remplacées par des pièces de rechange d'origine.
- Utilisez l'enrouleur uniquement aux fins indiquées.
- Ne pas altérer ni modifier l'enrouleur.
- Ne jamais lâcher le tuyau lors de son extraction ou de son enroulement.
- Ne jamais tenter de colmater des fuites du tuyau et de l'enrouleur avec la main ou tout autre partie du corps.

Attention:

Avant tout acte de maintenance ou de réparation, toujours couper l'arrivée des fluides et faire chuter la pression à l'intérieur de l'enrouleur.

2. Installation

Lors de l'installation de l'enrouleur, observez les points suivants :

- Utiliser le matériel de montage approprié pour supporter le poids de l'enrouleur. Veuillez en l'occurrence également prendre en compte le poids du liquide et la tension du ressort.
- Pour un montage au plafond (fig. 2), l'enrouleur ne doit pas pouvoir pivoter. Utilisez à cet effet la fixation fournie.
- Utilisez une vis M8x50 pour fixer le boulon du support mural. En alternative, il est également possible d'utiliser un cadenas.
- Établissez un raccordement étanche et sécurisé avec l'alimentation en liquide par le raccord latéral.
- Respectez la pression de travail maximale de l'enrouleur.
- Vérifiez l'étanchéité de l'enrouleur.

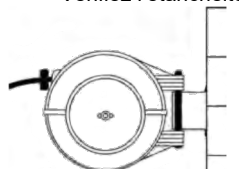

fig. 1 - montage mural, hauteur max. 1,4 m

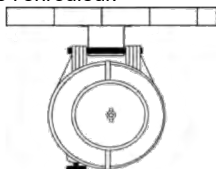

fig. 2 - montage au plafond, hauteur max 4,5 m

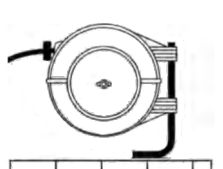

fig. 3 - montage au sol (accessoires)

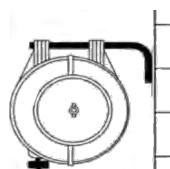

fig. 4 - montage mural, hauteur max. 4,5 m (accessoires)

3. Tendre le ressort

Attention: Avant d'effectuer toute opération de maintenance, l'enrouleur doit être mis hors pression. Le tuyau doit toujours être intégralement enroulé.

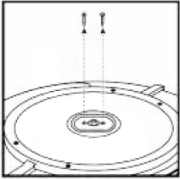

fig. 1 - desserrez les vis.



fig. 2 - tournez dans le sens des aiguilles d'une montre. 1 clic correspond à 90°

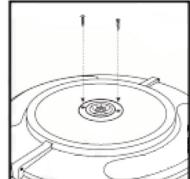

fig. 3 - serrez délicatement les 2 vis.

4. Remplacement du tuyau

Attention: Avant d'effectuer toute opération de maintenance, l'enrouleur doit être mis hors pression. Le tuyau doit toujours être intégralement déroulé..

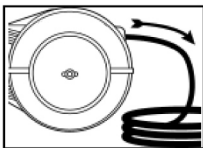

fig1. - extraire entièrement le tuyau et le bloquer

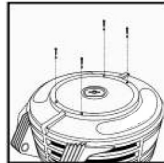

fig. 2 - desserrer les vis

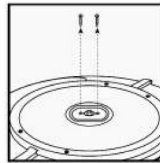

fig. 3 - desserrer les vis



fig. 4 - enlever le cache



fig. 5 - enlever les serre-câble

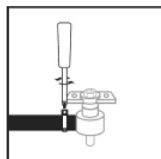

fig. 6 - enlever le tambour

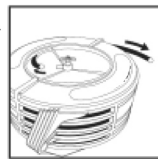

fig. 7 - enlever le tuyau



fig. 8 - mettre le nouveau tuyau en place

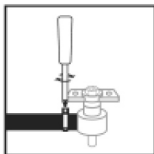

fig. 9 - monter le tuyau sur le tambour

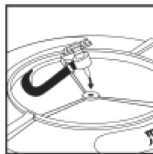

fig. 10 - mettre le tambour en place

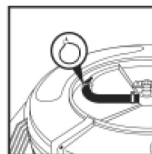

fig. 11 - mettre les serre-câbles en place

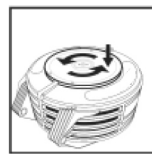

fig. 12 - monter le cache

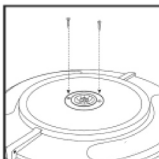

fig. 13 - serrer les vis

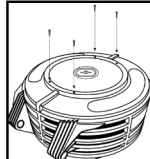

fig. 14 - serrer les vis

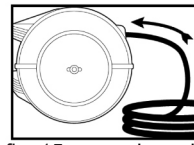

fig. 15 - enrouler uniformément le tuyau

5. Remplacement du tambour et du joint

Attention: Avant d'effectuer toute opération de maintenance, l'enrouleur doit être mis hors pression. Le tuyau doit toujours être intégralement déroulé.

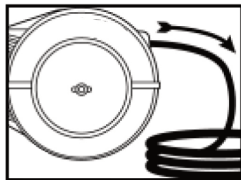

fig. 1 - extraire entièrement le tuyau et le bloquer

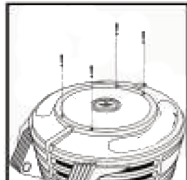

fig. 2 - desserrer les vis

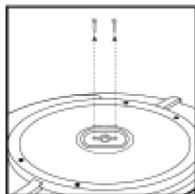

fig. 3 - desserrer les vis

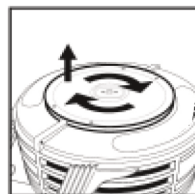

fig. 4 - enlever le cache



fig. 5 - enlever les serre-câbles

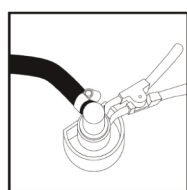

fig. 6 - enlever le circlip

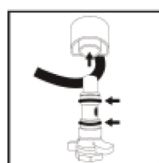

fig. 7 - enlever le tambour de l'axe. Lubrifier les joints toriques avant de les mettre en place. Monter le tuyau sur le tambour

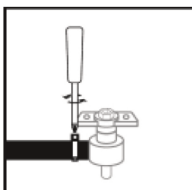

fig. 8 - monter le tuyau sur le tambour

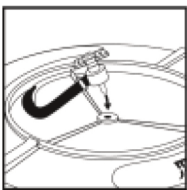

fig. 9 - mettre le tambour en place

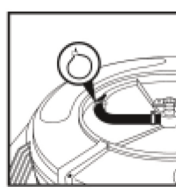

fig. 10 - mettre les serre-câbles en place



fig. 11 - monter le cache

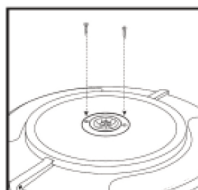

fig. 13 - serrer les vis

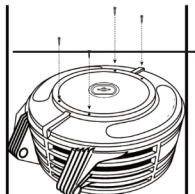

fig. 14 - serrer les vis

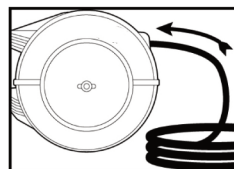

fig. 15 - enrouler uniformément le tuyau

6. Extraction / remplacement du cache

Attention: Avant d'effectuer toute opération de maintenance, l'enrouleur doit être mis hors pression. Le tuyau doit toujours être intégralement déroulé.

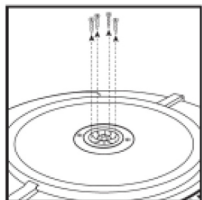

fig. 1 - desserrer les vis

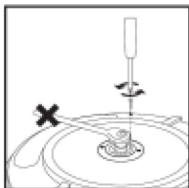

fig. 2 - le maintenir et desserrer 2 vis

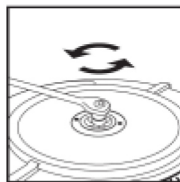

fig. 3 - détendre le ressort

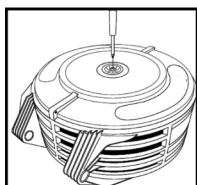

fig. 4 - desserrer les vis

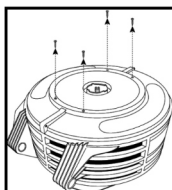

fig. 5 - le maintenir et desserrer 2 vis

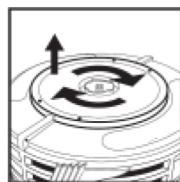

fig. 6 - enlever le cache



fig. 7 - mettre le nouveau cache en place

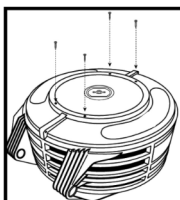

fig. 8 - serrer les vis

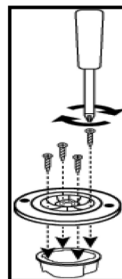

fig. 9 - serrer les vis

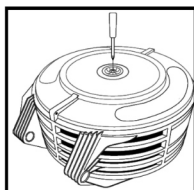

fig. 10 - mettre les vis en place

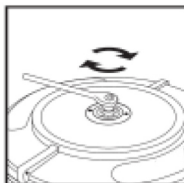

fig. 11 - opérer 3 tours

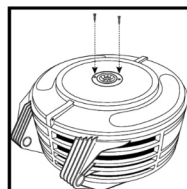
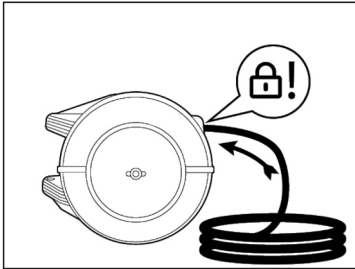

fig. 12 - serrer les vis

7. Résolution de problèmes



Problème:

Le tuyau se rétracte lentement ou pas entièrement

- a) L'outil / la buse à l'extrémité du tuyau est trop lourd(e)
- b) Le ressort a perdu de sa tension

Solution:

Retendre le ressort (voir point 3)

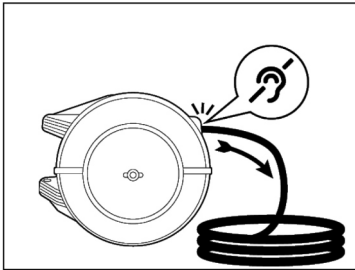

Problème:

L'enrouleur ne se verrouille pas

- a) Fonctionnement défectueux
- b) Dispositif de verrouillage défectueux

Solution:

Remplacer le dispositif de verrouillage (voir point 6)

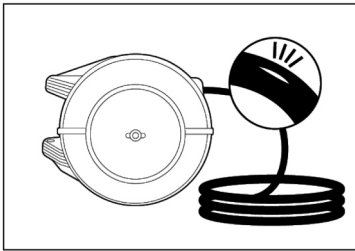

Problème:

Le tuyau fuit

- a) Tuyau défectueux

Solution:

Remplacer le tuyau (voir point 4)

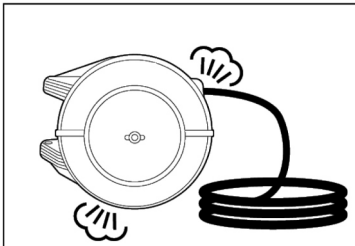

Problème:

Le tambour fuit

- a) Tambour ou joint défectueux

Solution:

Remplacer le tambour ou le joint (voir point 5)

 **Lea detenidamente el manual de instrucciones antes de utilizar el equipo!**

1. Indicaciones generales

El carrete de manguera está equipado con un muelle de recuperación para enrollar la manguera. La manguera se puede fijar en cada vuelta mediante un sistema de enclavamiento. El carrete de manguera debe utilizarse únicamente para enrollar mangueras. En función del modelo solo pueden utilizarse mangueras para los medios especificados a continuación y con la presión de trabajo correspondiente.

Modelo	Medio/ temp. máxima	Presión máxima
DR 100 - 300 R3	agua fría + 50°C	8 bar
DR 110 R3	agua fría + 50°C	8 bar
AR 100 - 200 R3	air comprimido + 50°C	17 bar
HWP 100 R3	agua caliente + 50°C	200 bar
WP 100 R3	plaguicida + 50°C	17 bar

Tenga en cuenta las siguientes indicaciones durante la instalación, la puesta en servicio y el mantenimiento del carrete de manguera. En las presentes instrucciones de uso también encontrará indicaciones adicionales sobre posibles peligros especiales.

- No supere la presión de trabajo especificada para el carrete de manguera bajo ningún concepto.
- La manguera y el carrete de manguera solo deben entrar en contacto con los líquidos para los cuales han sido autorizados
- Compruebe diariamente el desgaste y la existencia de fugas en la manguera y el carrete de manguera. Las piezas defectuosas deben sustituirse de inmediato utilizando únicamente repuestos originales.
- Utilice el carrete de manguera solo para el uso previsto.
- No modifique ni altere el carrete de manguera.
- No deje suelta la manguera bajo ningún concepto al extraerla o enrollarla.
- No intente detener las fugas de la manguera o el carrete de manguera con la mano u otras partes del cuerpo.

Atención:

Antes del mantenimiento o la reparación, desconecte el suministro del medio y elimine toda la presión del carrete de manguera.

2. Installation

Tenga en cuenta los siguientes puntos durante la instalación del carrete de manguera:

- Utilice material de montaje apto para soportar el peso del carrete de manguera. Tenga en cuenta también el peso del líquido y la tensión del muelle.
- Si efectúa el montaje en el techo (fig. 2), el carrete de manguera no debe poder girar. Utilice para ello el elemento de fijación suministrado.
- Utilice un tornillo M8x50 para fijar el perno del soporte de pared. También puede utilizar un candado.
- Conecte el suministro de líquido a través de la toma lateral garantizando una unión segura y hermética. Respete la presión de trabajo máxima del carrete de manguera.
- Compruebe si el carrete de manguera presenta fugas.

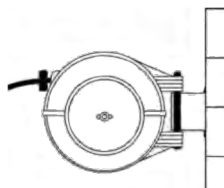

fig. 1 - montaje en pared, altura max. 1,4 m

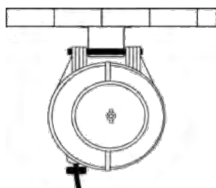

fig. 2 - montaje en el techo, altura max. 4,5 m

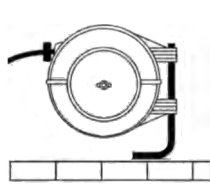

fig. 3 - montaje en el suelo (accesorio)

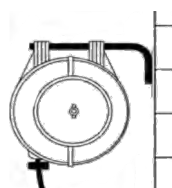

fig. 4 - montaje en el techo, altura max. 4,5 m (accesorio)

3. Tensión del muelle

Atención: Antes de realizar los trabajos de mantenimiento, es necesario eliminar toda la presión del carrete de manguera. La manguera debe estar siempre completamente enrollada.

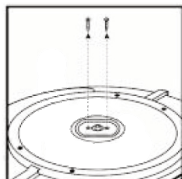

fig. 1 - retire los tornillos

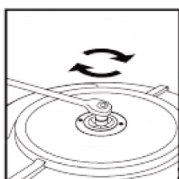

fig. 2 - gírelos en el sentido de las agujas del reloj. 1 "clic" equivale a 90°

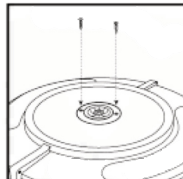

fig. 3 - apriete con cuidado los 2 tornillos

4. Sustitución de la manguera

Atención: Antes de realizar los trabajos de mantenimiento, es necesario eliminar toda la presión del carrete de manguera. La manguera debe estar siempre completamente enrollada.

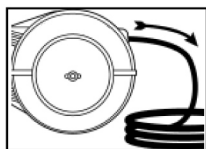

fig1. - extraiga completamente la manguera y bloquéela

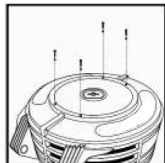

fig. 2 - retire los tornillos

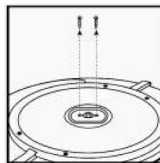

fig. 3 - retire los tornillo



fig. 4 - extraiga la tapa

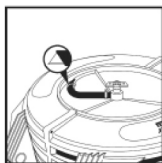

fig. 5 - retire el sujetacables

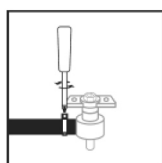

fig. 6 - retire el pivote



fig. 7 - retire la manguera



fig. 8 - coloque la manguera

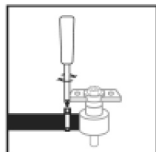

fig. 9 - monte la manguera en el pivote



fig. 10 - instale el pivote

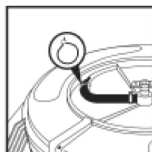

fig. 11 - coloque el sujetacables

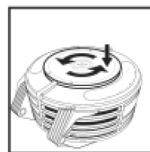

fig. 12 - monte la tapa

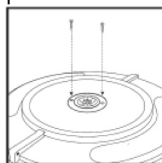

fig. 13 - apriete los tornillos

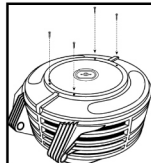

fig. 14 - apriete los tornillos

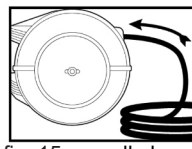

fig. 15 - enrolle la manguera de forma homogénea

5. Sustitución del pivote y de la junta

Atención: Antes de realizar los trabajos de mantenimiento, es necesario eliminar toda la presión del carrete de manguera. La manguera debe estar siempre completamente enrollada.

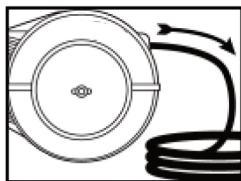

fig. 1 - extraiga completamente la manguera y bloquéela

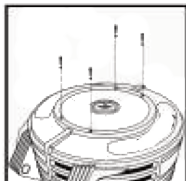

fig. 2 - retire los tornillos

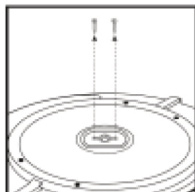

fig. 3 - retire los tornillos



fig. 4 - extraiga la tapa



fig. 5 retire el sujetacables

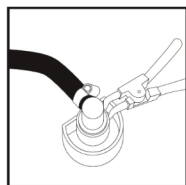

fig. 6 - retire el anillo de retención



fig. 7 - retire el pivote del eje.
Lubrique y coloque las juntas tóricas

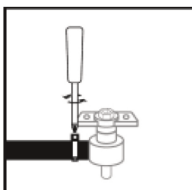

fig. 8 - monte la manguera en el pivote



fig. 9 - instale el pivote

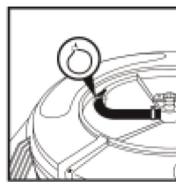

fig. 10 - coloque el sujetacables



fig. 11 - monte la tapa

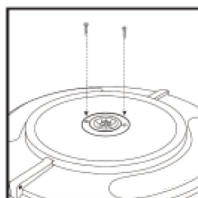

fig. 13 - apriete los tornillos

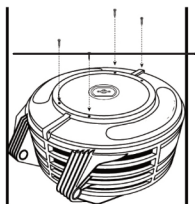

fig. 14 - apriete los tornillos

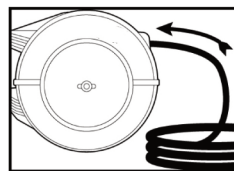

fig. 15 - enrolle la manguera de forma homogénea

6. Extracción / sustitución de la tapa

Atención: Antes de realizar los trabajos de mantenimiento, es necesario eliminar toda la presión del carrete de manguera. La manguera debe estar siempre completamente enrollada.

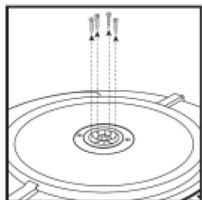

fig. 1 - retire los tornillos

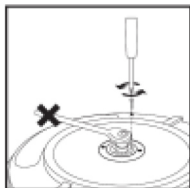

fig. 2 - sujétela y retire 2 tornillos

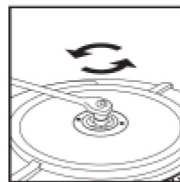

fig. 3 - elimine la tensión del muelle

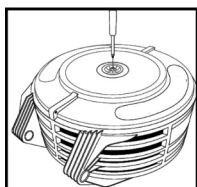

fig. 4 - retire los tornillos

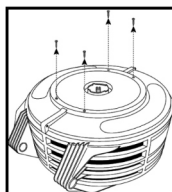

fig. 5 - sujétela y retire 2 tornillos

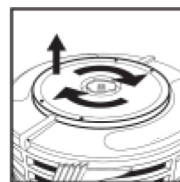

fig. 6 - extraiga la tapa



fig. 7 - coloque la tapa nueva

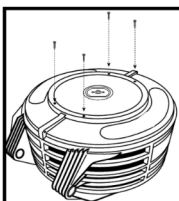

fig. 8 - apriete los tornillos

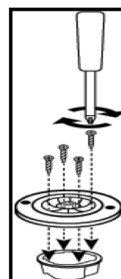

fig. 9 - apriete los tornillos

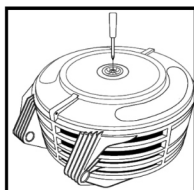

fig. 10 - apriete los tornillos

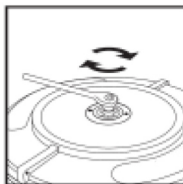

fig. 11 - apriételos efectuando 3 giros

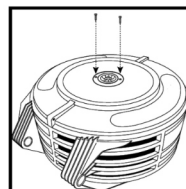
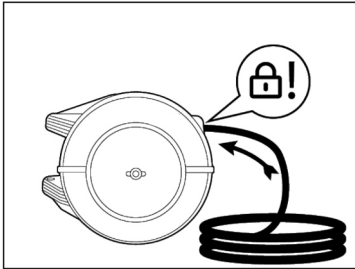

fig. 12 - apriete los tornillos

7. Resolución de problemas



Problema:

La manguera no se retrae completamente o lo hace muy despacio

- a) La boca/herramienta situada en el extremo de la manguera es demasiado pesada
- a) El muelle está destensado

Solución:

Vuelva a tensar el muelle (véase el capítulo 3)

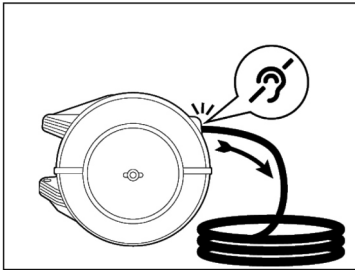

Problema:

El carrete de manguera no se bloquea

- a) Funcionamiento defectuoso
- b) Sistema de enclavamiento defectuoso

Solución:

Sustituya el sistema de enclavamiento (véase el capítulo 6)

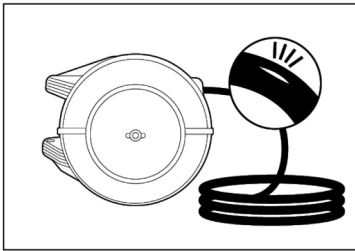

Problema:

La manguera tiene fugas

- a) Manguera defectuosa

Solución:

Sustituya la manguera (véase el capítulo 4)

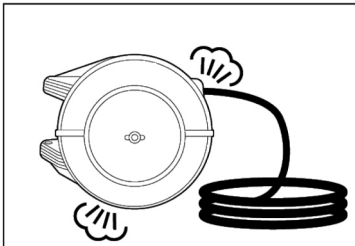

Problema:

El pivote tiene fugas

- a) Pivote o junta defectuosos

Solución:

Sustituya el pivote o la junta (véase el capítulo 5)



Leggere attentamente il libretto di istruzioni prima di mettere in funzione l'attrezzatura!

1. Indicazioni generali

L'avvolgitore per tubi flessibili è provvisto di una molla di richiamo atta all'avvolgimento del tubo flessibile. Mediante il dispositivo di arresto è possibile bloccare il tubo flessibile in seguito a ogni rotazione completa. L'avvolgitore per tubi flessibili è destinato unicamente all'avvolgimento di tubi flessibili. I diversi modelli richiedono l'utilizzo esclusivamente di tubi flessibili idonei per i fluidi indicati di seguito e alla pressione di esercizio corrispondente.

Modello	Fluido/ temp. massima	Pressione massima
DR 100 - 300 R3	acqua fredda + 50°C	8 bar
DR 110 R3	acqua fredda + 50°C	8 bar
AR 100 - 200 R3	aria compressa + 50°C	17 bar
HWP 100 R3	acqua calda + 50°C	200 bar
WP 100 R3	pesticidi + 50°C	17 bar

Le indicazioni a seguire devono essere rispettate durante l'installazione, la messa in funzione e la manutenzione dell'avvolgitore per tubi flessibili. Ulteriori indicazioni in merito a pericoli speciali sono fornite successivamente nelle presenti istruzioni per l'uso.

- Non superare mai la pressione di esercizio indicata sull'avvolgitore per tubi flessibili.
- Il tubo flessibile e l'avvolgitore devono entrare in contatto solo con liquidi per cui sono idonei.
- Verificare quotidianamente che il tubo flessibile e l'avvolgitore siano a tenuta e privi di segni di usura. Le parti difettose devono essere sostituite immediatamente e soltanto con ricambi originali.
- Impiegare l'avvolgitore per tubi flessibili esclusivamente per l'uso previsto.
- Non modificare o alterare l'avvolgitore per tubi flessibili.
- Non rilasciare il tubo flessibile durante lo svolgimento e l'avvolgimento.
- Non cercare mai di coprire eventuali perdite sul tubo flessibile o sull'avvolgitore con le mani o altre parti del corpo.

Attention:

Prima di eseguire qualsiasi intervento di manutenzione o riparazione, staccare sempre l'alimentazione del fluido e "depressurizzare" l'avvolgitore.

2. Installare l'avvolgitore

Utilizzare materiale di montaggio idoneo a sorreggere il peso dell'avvolgitore per tubi flessibili. Tenere conto anche del peso del liquido e della tensione della molla.

- In caso di montaggio sul soffitto (Fig. 2), l'avvolgitore non deve risultare girevole. Impiegare in questo caso il materiale di fissaggio fornito in dotazione.
- Utilizzare una vite M8x50 per fissare il perno del supporto a muro. In alternativa è possibile ricorrere anche a un lucchetto.
- Stabilire un collegamento sicuro e a tenuta per l'alimentazione del liquido con l'attacco laterale. Rispettare la pressione di esercizio massima dell'avvolgitore per tubi flessibili.
- Verificare che l'avvolgitore per tubi flessibili sia a tenuta

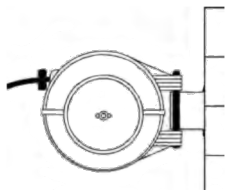

fig. 1 - montaggio a muro, altezza massima 1,4 m

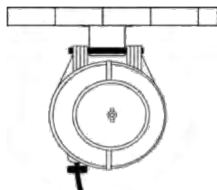

fig. 2 - montaggio sopra la testa, altezza massima 4,5 m

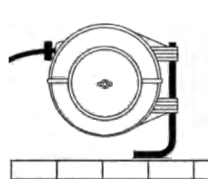

fig. 3 - montaggio a pavimento (accessoi)

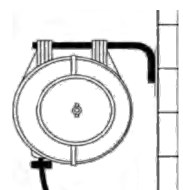

fig. 4 - montaggio a muro, max. height altezza massima 4,5 m (accessoi)

3. Tendere la molla

Attenzione: Prima di eseguire qualsiasi operazione di manutenzione è necessario "depressurizzare" l'avvolgitore per tubi flessibili. Avvolgere completamente il tubo flessibile prima di procedere con l'intervento.

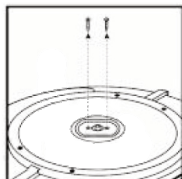

fig. 1 - allentare le viti

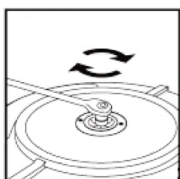

fig. 2 - ruotare la molla in senso orario. 1 "clic" corrisponde a 90°

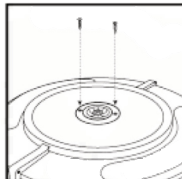

fig. 3 -avvitare le 2 viti con cautela

4. Sostituire il tubo flessibile

Attenzione: Prima di eseguire qualsiasi operazione di manutenzione è necessario "depressurizzare" l'avvolgitore per tubi flessibili. Avvolgere completamente il tubo flessibile prima di procedere con l'intervento.

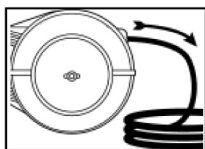

fig1. - estrarre completamente il tubo flessibile e bloccarlo

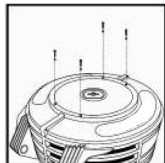

fig. 2 - allentare le viti

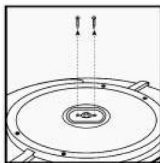

fig. 3 - allentare le viti



fig. 4 - rimuovere il coperchio

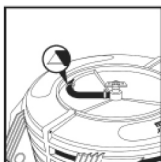

fig. 5 -rimuovere la fascetta serracavi

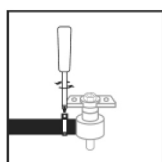

fig. 6 - rimuovere il raccordo girevole



fig. 7 - rimuovere il tubo flessibile



fig. 8 - inserire il tubo flessibile

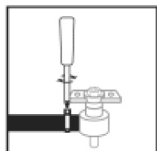

fig. 9 - collegare il tubo flessibile al raccordo girevole

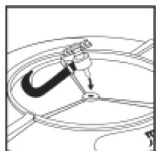

fig. 10 - montare il raccordo girevole

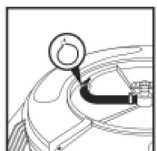

fig. 11 - montare la fascetta serracavi



fig. 12 - montare il coperchio

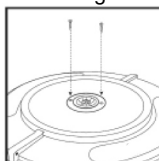

fig. 13 - avvitare le viti

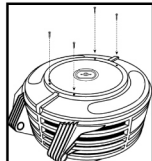

fig. 14 - avvitare le viti

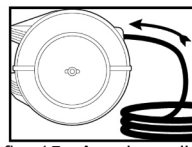

fig. 15 - Avvolgere il tubo flessibile in maniera uniforme

5. Sostituire il raccordo girevole e la guarnizione

Attenzione: Prima di eseguire qualsiasi operazione di manutenzione è necessario "depressurizzare" l'avvolgitore per tubi flessibili. Avvolgere completamente il tubo flessibile prima di procedere con l'intervento.

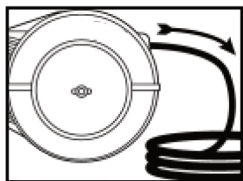

fig. 1 - estrarre completamente il tubo flessibile e bloccarlo

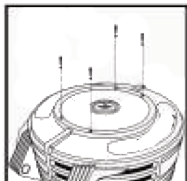

fig. 2 - allentare le viti

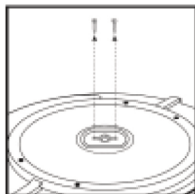

fig. 3 - allentare le viti



fig. 4 - rimuovere il coperchio



fig. 5 - rimuovere la fascetta serracavi

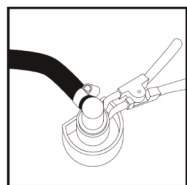

fig. 6 - rimuovere l'anello Seeger



fig. 7 - Rimuovere il raccordo girevole dall'asse. Inserire gli O-ring lubrificandoli in precedenza

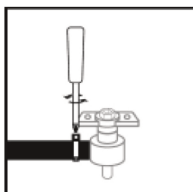

fig. 8 - collegare il tubo flessibile al raccordo girevole



fig. 9 - montare il raccordo girevole

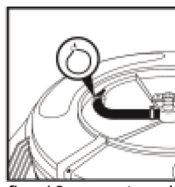

fig. 10 - montare la fascetta serracavi



fig. 11 - montare il coperchio



fig. 13 - avvitare le viti

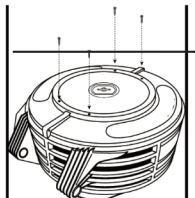

fig. 14 - avvitare le viti

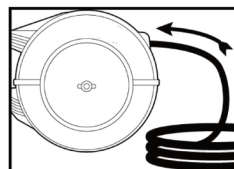

fig. 15 - avvolgere il tubo flessibile in maniera uniforme

6. Rimuovere / sostituire il coperchio

Attenzione: Prima di eseguire qualsiasi operazione di manutenzione è necessario "depressurizzare" l'avvolgitore per tubi flessibili. Avvolgere completamente il tubo flessibile prima di procedere con l'intervento.

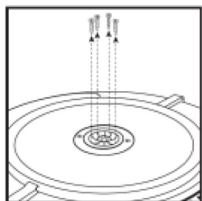

fig. 1 - allentare le viti

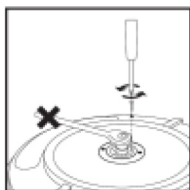

fig. 2 - mantenere fermo il coperchio e allentare le 2 viti

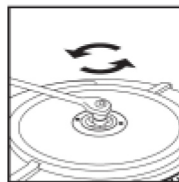

fig. 3 - scaricare la molla

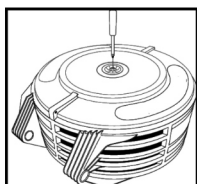

fig. 4 - allentare le viti

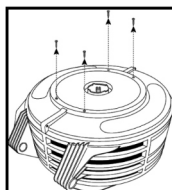

fig. 5 - Mantenere fermo il coperchio e allentare le 2 viti

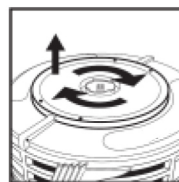

fig. 6 - rimuovere il coperchio

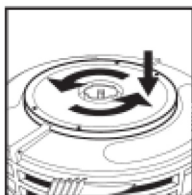

fig. 7 - applicare il nuovo coperchio

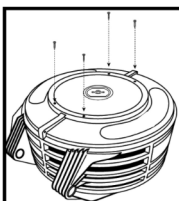

fig. 8 - inserire le viti

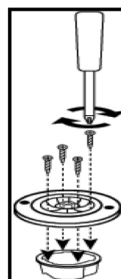

fig. 9 - inserire le viti

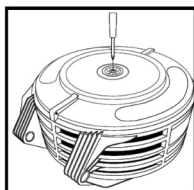

fig. 10 - inserire le viti

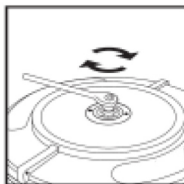

fig. 11 - tendere la molla con 3 rotazioni complete

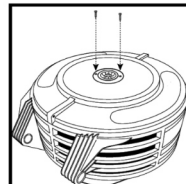
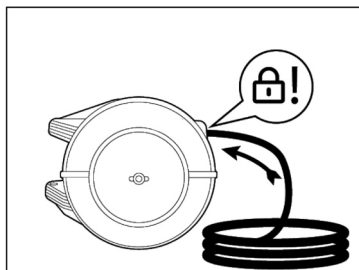

fig. 12 - inserire le viti

7. Risoluzione dei problemi



Problema:

Il tubo flessibile rientra lentamente oppure solo in parte

- a) L'ugello o l'elemento all'estremità del tubo flessibile è troppo pesante
- a) La molla si è scaricata

Soluzione:

Tendere la molla (vedi capitolo 3)

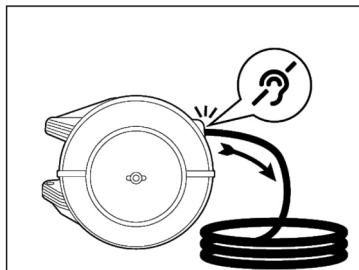

Problema:

L'avvolgitore non si arresta

- a) Funzionamento scorretto
- b) Dispositivo di arresto difettoso

Soluzione:

Sostituire il dispositivo di arresto (vedi capitolo 6)

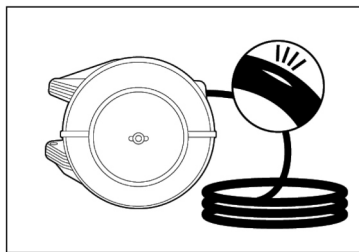

Problema:

Il tubo flessibile non è a tenuta

- a) Tubo flessibile difettoso

Soluzione:

Sostituire il tubo flessibile (vedi capitolo 4)

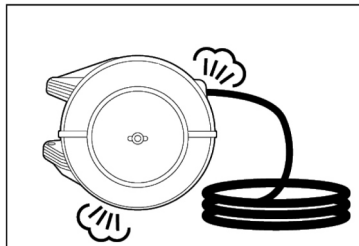

Problema:

Il raccordo girevole non è a tenuta

- a) Raccordo girevole o guarnizione difettoso

Soluzione:

Sostituire il raccordo girevole o la guarnizione (vedi capitolo 5)

- DE** Konformitätserklärung nach Vorgabe von Anhang II Teil der Maschinenrichtlinie 2006/42/EG
- GB** Declaration of conformity in accordance with annex II part A of directive 2006/42/EC
- FR** Déclaration UE de conformité aux termes de l'annex II partie A de la directive 2006/42/CE
- ES** Declaración UE de conformidad con arreglo al anexo II parte A de la directiva 2006/42/CE
- IT** Dichiarazione UE di conformità ai sensi dell'art. II parte A della direttiva 2006/42/CE

Ebinger GmbH

Technisches Equipment
Edesheimer Str. 51
DE-76835 Rhodt / Germany

- DE** erklärt, dass die unten genannten Maschinen in allen Teilen den Vorgaben der geltenden europäischen Richtlinie entsprechen: 2006/42/EG (Maschinenrichtlinie).
- GB** declares that the equipment models indicated below are compliance in all their parts with the following applicable european directives: 2006/42/EG (the Machinery Directive)
- FR** declare que les modèles de machine indiqués ci-dessous sont conformes dans toutes leurs parties aux directives européennes applicables suivantes: 2006/42/CE (directive machines)
- ES** declara que los modelos de máquina indicados abajo están conformes en todas las partes con las siguientes directivas europeas aplicables: 2006/42/CE (la directiva sobre maquinaria)
- IT** dichiara che i modelli di macchina sotto indicati sono conformi in tutte le loro parti alle seguenti direttive europee applicabili: 2006/42/CE (direttive europee applicabili)

**Schlauchaufroller / hose reel / enrouleur / enrolladore /
avvolgitubo DR 100-300 R3, DR 110 R3, AR 100 - 200 R3,
HWP 100 R3, WP 100 R3**

- DE** Zur sachgerechten Umsetzung der in der EG-Richtlinien genannten Sicherheits- und Gesundheitsanforderungen wurden folgende Normen angewendet: EN ISO 12100:2010 (Maschinensicherheit)
- GB** The following standards have been applied for the proper implementation of the health and safety requirements specified in the EC Directives: EN ISO 12100:2010 (Safety of Machinery)
- FR** Afin de mettre en œuvre de manière appropriée les exigences de sécurité et de santé visées par les directives communautaires, les normes suivantes ont été appliquées: EN ISO 12100:2010 (sécurité Machines)
- ES** Se han aplicado las siguientes normas para la correcta aplicación de los requisitos de seguridad y salud especificados en las directivas de la CE: EN ISO 12100:2010 (seguridad de la maquinaria)
- IT** Per la corretta attuazione dei requisiti di salute e sicurezza specificati nelle Direttive CE sono state applicate le seguenti norme: EN ISO 12100:2010 (Sicurezza delle macchine)

Datum / Date /
Fecha / Data
11/2021

Geschäftsführer / managing director / directeur
général / director general / amministratore delegato



Markus Ebinger

Notizen / notes / notas / note
